

ENVIROFLEX® - BASIN ACCESS ROAD

TAPERED, VERTICALLY INTERLOCKING ARTICULATING CONCRETE BLOCK (ACB) SYSTEM

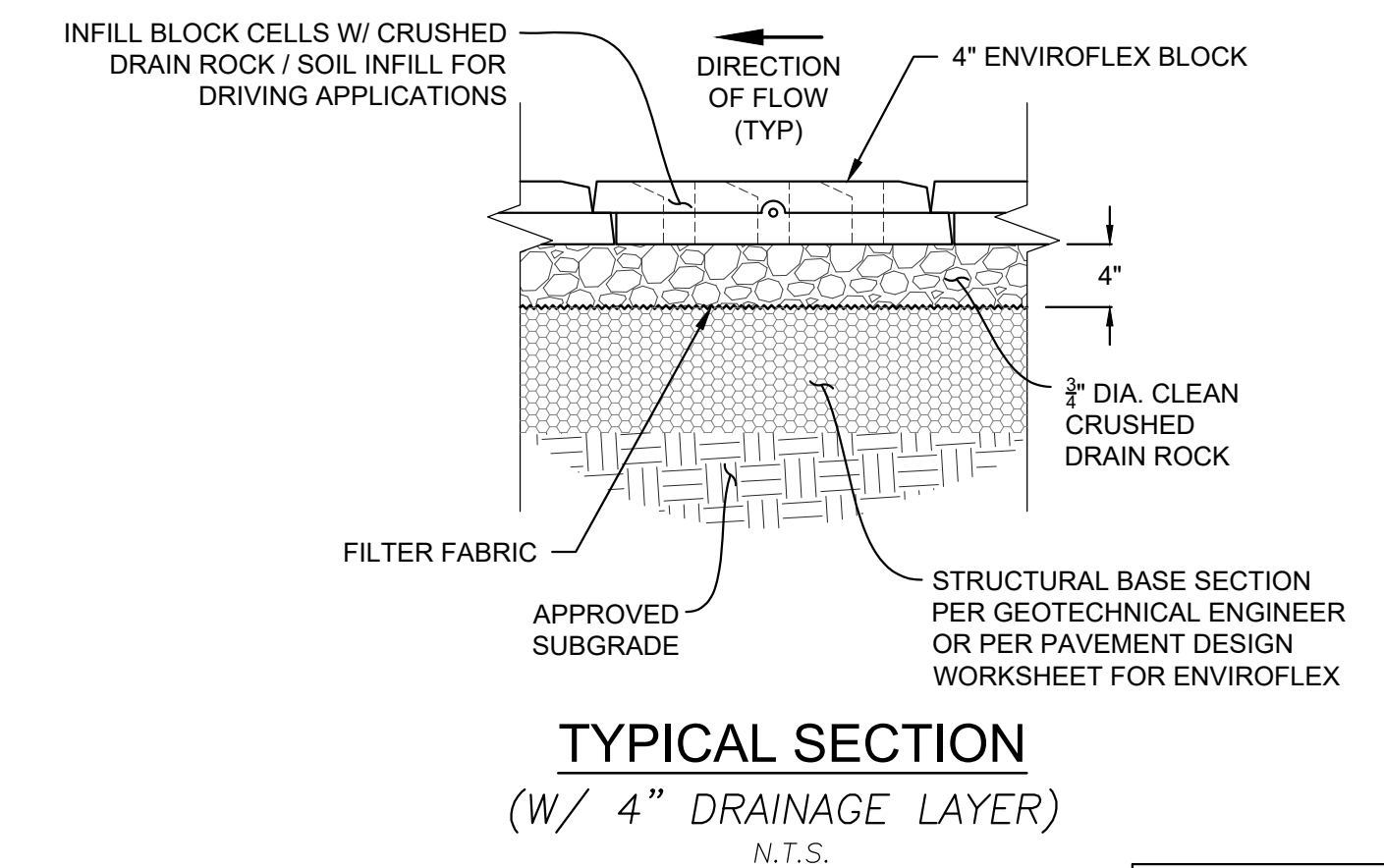
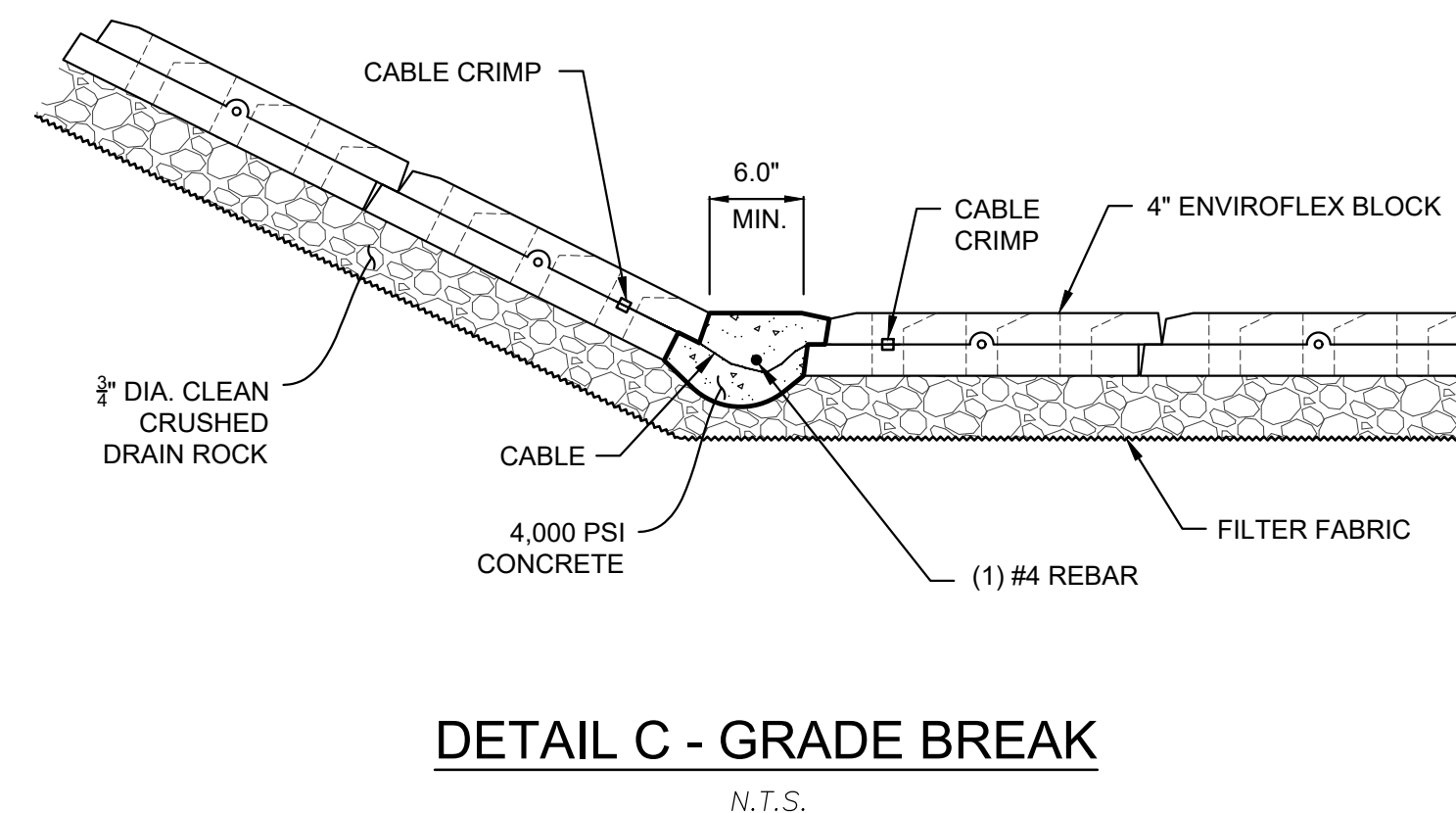
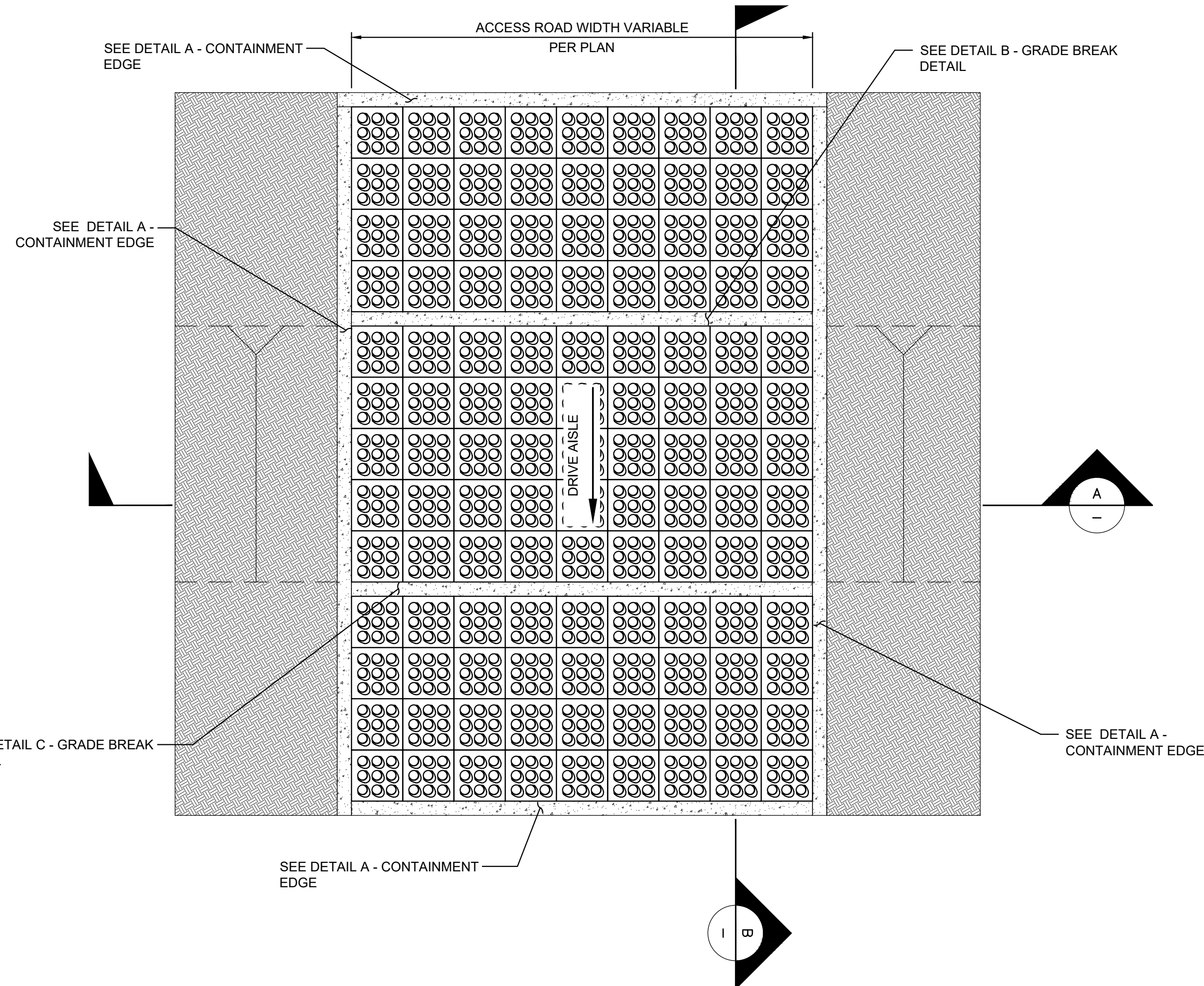
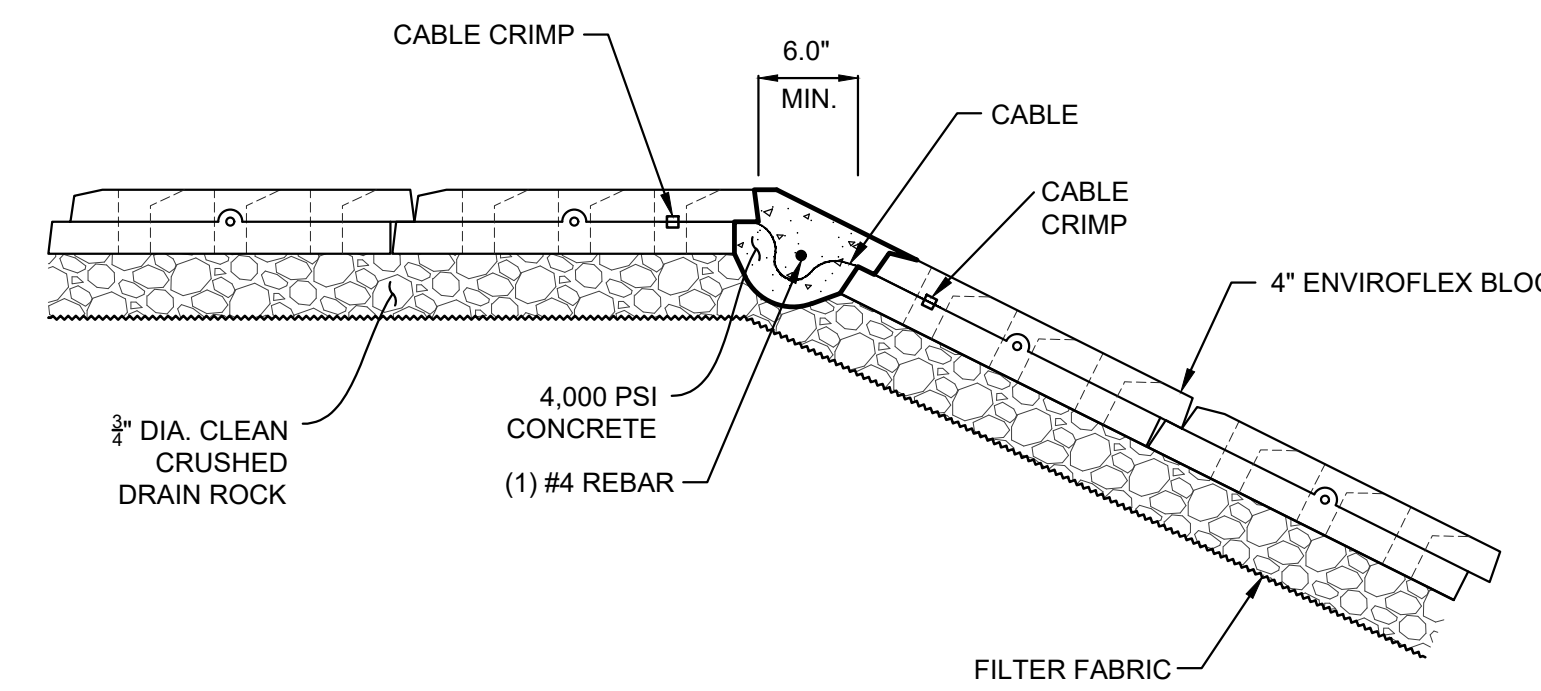
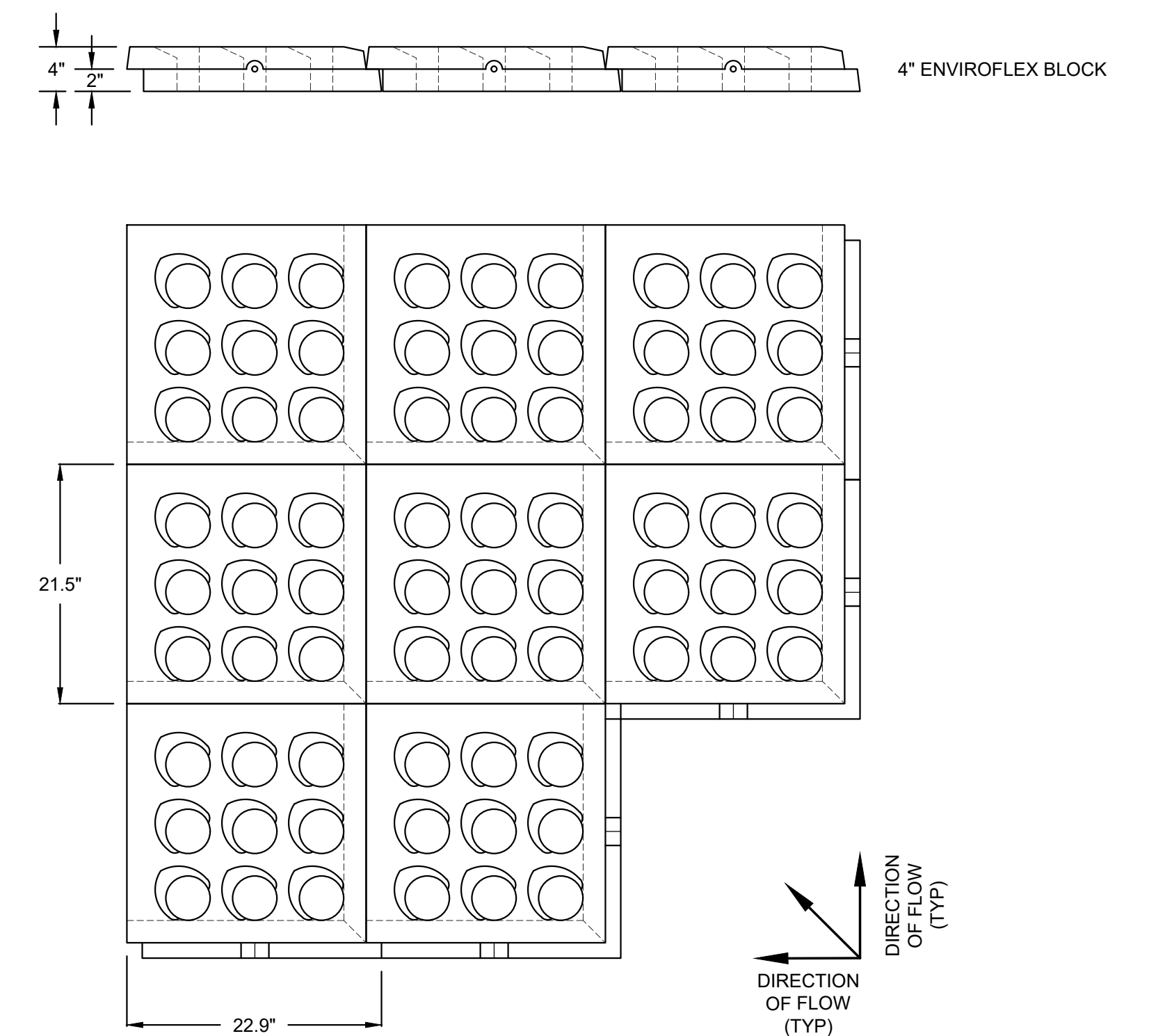
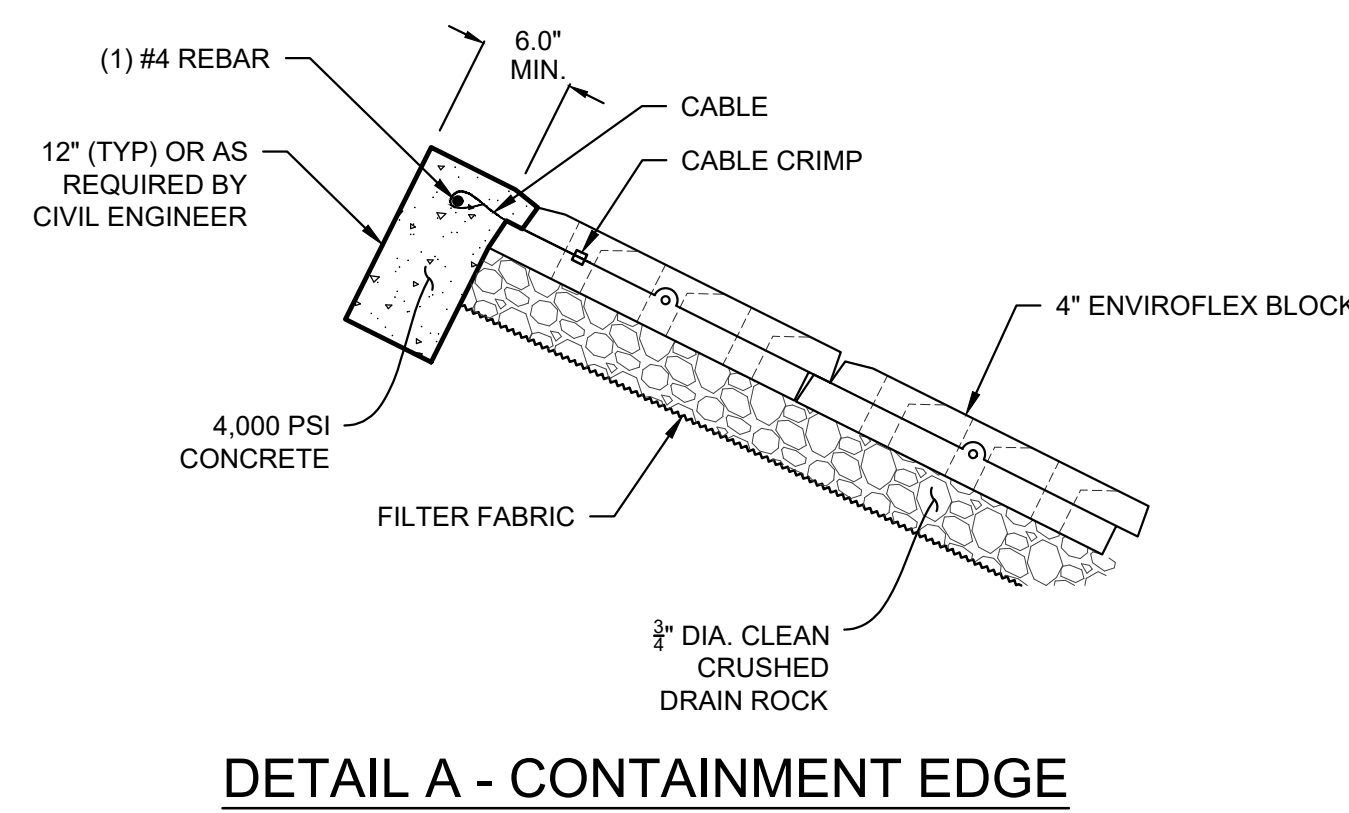
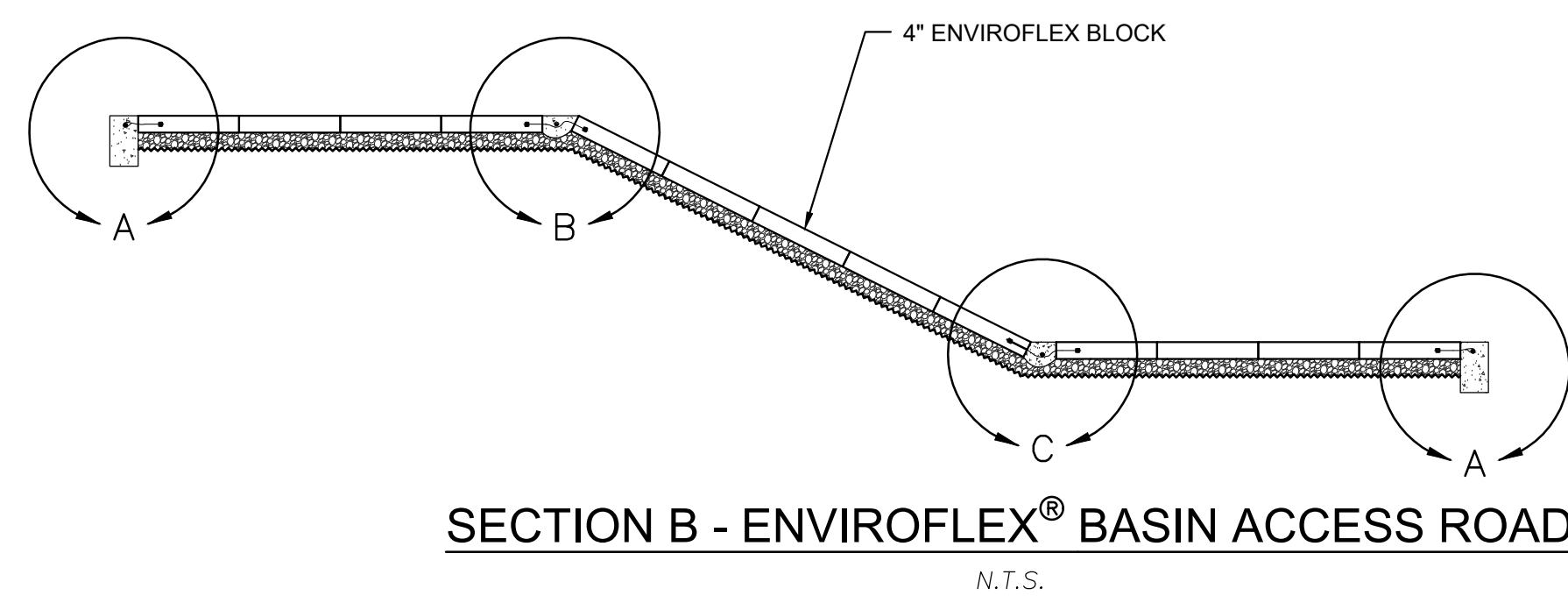
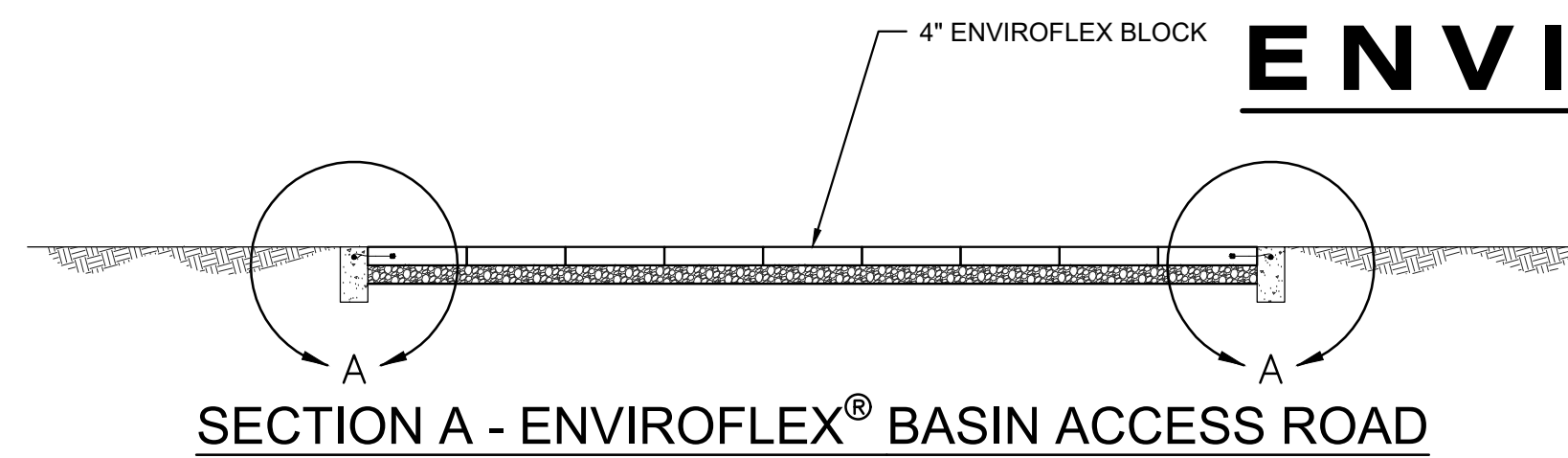

4" ENVIROFLEX DESIGN CRITERIA		
W/ 4" DRAINAGE LAYER		
CRITICAL SHEAR STRESS	PSF	18
VELOCITY LIMIT	FT/SEC	23.3

NO CONNECTORS OR CABLES WERE USED IN THE TESTING FOR THE VALUES LISTED ABOVE.

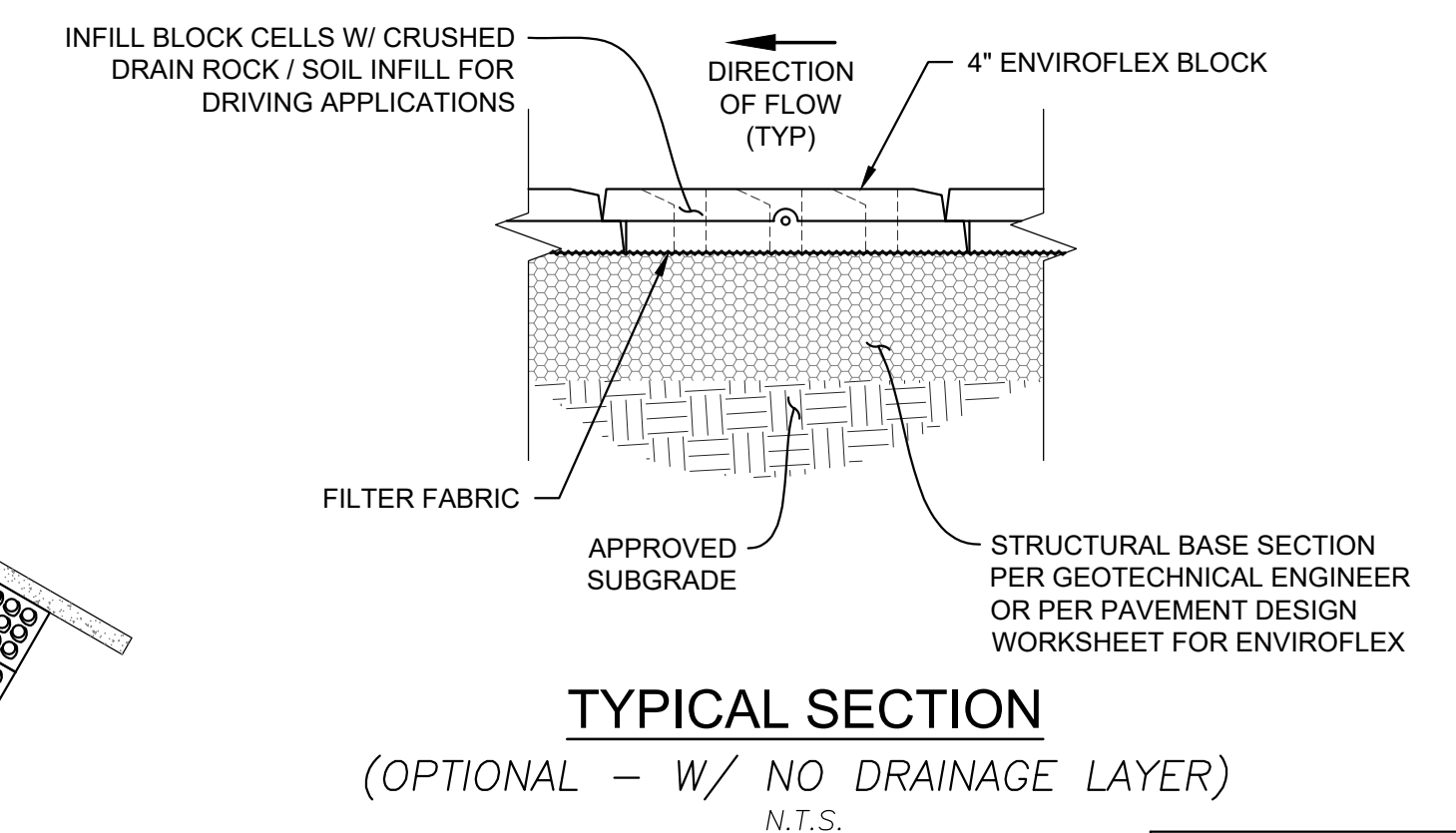
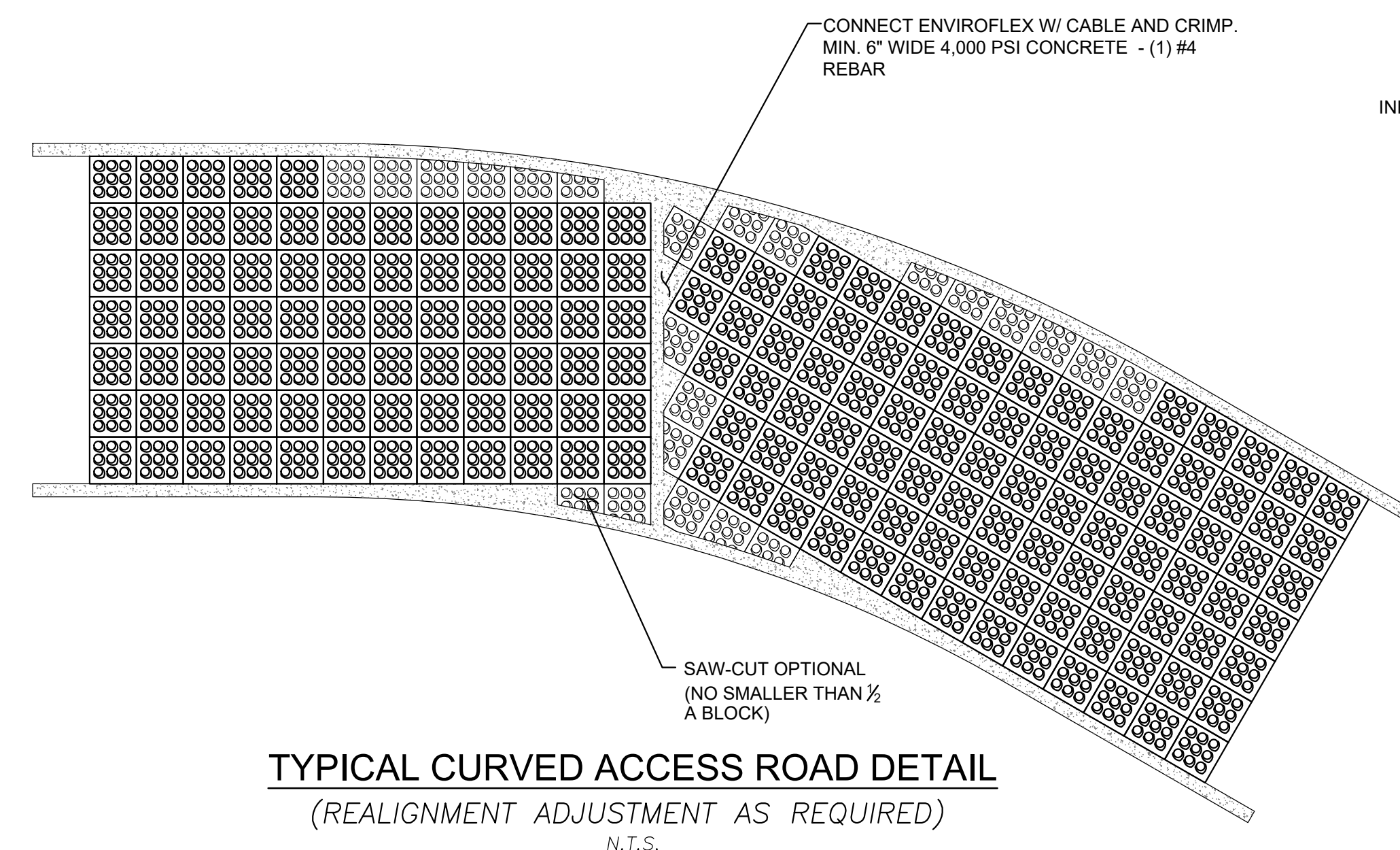

4" ENVIROFLEX DESIGN CRITERIA		
W/ NO DRAINAGE LAYER		
CRITICAL SHEAR STRESS	PSF	6.2
VELOCITY LIMIT	FT/SEC	12.1

NO CONNECTORS OR CABLES WERE USED IN THE TESTING FOR THE VALUES LISTED ABOVE.

